

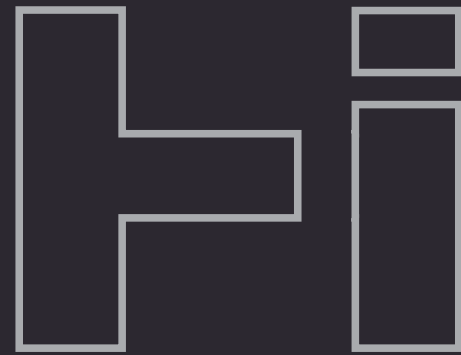

HUNNY IMPEX
WAVE WOOD YOUR WAY



Rectifying Panel Processing

An Atelier of **MODULAR & SOLID WOOD** Machines



CUTTING

DRILLING

EDGE BANDING

PROFILING

An Atelier of **MODULAR & SOLID WOOD** Machines



WHEN YOU NEED TECHNOLOGY AND EXPERIENCE

We are ready to commit our team to meet your requirements. We have the capability to turn your concepts into reality. Being a leader in wood working tools manufacturing **YASH TOOLING SYSTEM** is now ready to set new benchmark in wood working machinery by our joint venture company **HUNNY IMPEX**. We manufacture machines with such high end precise technology which helps to reduce cutting cycle time and also increases the quantity, quality & smoothness of the cut surfaces. We ensure you unbeatable productivity and continuous operations by our sturdy machines design with premium & precise components

FLEXIBILITY

Apart from standard specific machines, we also provide customizable machines to meet the requirements of the customer .

QUALITY

High-tech level of production line and mounting high quality components from recognized suppliers.

CUSTOMER CARE

We are providing 24/7 assistance and after sales service with our widely service team network.

RESPONSIVENESS & SERVICES

Our every dealership is fully stocked with spares & tools of machines which provides "instant response" Training sessions on site and at production plant with 24/7 online technical assistance at sites.

OUR MISSION

To design high end revolutionary machines for our customer that will give satisfactory solutions.

WE RELY ON TRUST AND QUALITY.



UNFOLD TO KNOW
WHY HUNNY IMPEX IS THE
MOST PREFERRED PARTNER FOR PRODUCTIVITY



Rectifying Panel Processing

INDEX

Panel Saw	04
Multi Boring	06
Hinge Boring	08
Post Form	08
Spindle Moulder.....	09
Cold Press	10
Hot Press	11
Vacuum Mem. Press	11
High Speed Router	12
Dust Collector	12
Manual Corner Rounding.....	12
Manual Edge Bander.....	13
Portable Edge Bander.....	13
Auto Edge Bander.....	14
CNC Router	22
Double Head CNC Router	24
R+ATC+Boring CNC Router	25
CNC Nesting	26
CNC ATC+ Boring	27
CNC Horizontal Boring	28
High Speed Beam Saw	29
Six Side CNC Boring.....	33
Solutions for Mass Production	34
Mortiser and Tenoner	36
Wood Working Tools	37
Spare Parts	38



An Atelier of **MODULAR & SOLID WOOD** Machines

Note :

- with the continues products improvements the technical specifications are subject to change without prior information
- some accessories shown in machine may not be part of standard accessories

FULL FUNCTION HIGH EFFICIENT EXCELLENT PRECISION

PANEL SAW

Hi-320

Panel Saw



- Salient Features**
- Digital Display for the saw blade angle tilting
 - Manual control main saw and scoring saw angle tilt
 - Electric controlled main saw and scoring saw up & down

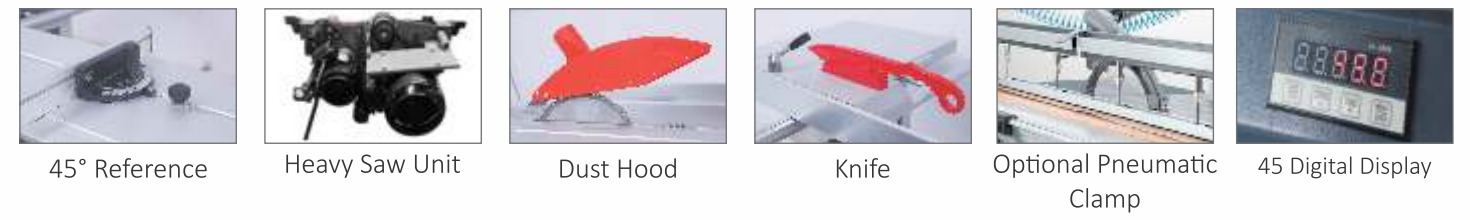

Hi-320 Extreme Saw

Panel Saw



- Salient Features**
- Precise cut with **chip free cutting**
 - Easy & quick scoring unit **up-down** and lateral movement
 - Central lubrication system which gives smooth & precise movement



FULL FUNCTION HIGH EFFICIENT EXCELLENT PRECISION

PANEL SAW

Hi-320 AUTO

Panel Saw



- Salient Features**
- Precise cut with **chip free cutting**
 - Smart and heavy duty structure
 - Smart touch **PLC Control Panel** for easy operation
 - High precision and long life **sliding table** for work
 - Easy & quick scoring unit **up-down** and lateral movement
 - Central lubrication system which gives smooth & precise movement
 - The machine body is processed by laser cutting, CNC bending machine, which can assure the accuracy, and not easy to be out of shape.
 - The main saw assembly and scoring saw assembly with dust prevention



SPECIFICATION	Hi-320	Hi-320 Extreme	Hi-320 AUTO
Dimesions Of Sliding Table	3200x370mm	3200x410mm	3200x435mm
Gross Cut Capacity	3200mm	3200mm	3200mm
Width Of Cut Between Saw Blade And Rip Fence	1250mm	1250mm	1300mm
Saw Blade Diameter	Φ300mmx30mm (Φ250-Φ350)	Φ300mmx30mm (Φ250-Φ350)	Φ300mmx30mm (Φ250-Φ350)
Height Of Cut	80/100mm	80/100mm	80/100mm
Speed Of Main Saw blade	4000/5000rpm	3000/4000/5000rpm	3000/4000/5000rpm
Tilting Saw Blade	90°-45° (Manual)	90°-45° (Manual)	90°-45° (Auto)
Main Motor	5.5kw (7.5HP)	5.5kw (7.5HP)	5.5kw (7.5HP)
Scoring Saw Blade Diam.	Φ120mmx20mm	Φ120mmx20mm	Φ120mmx20mm
Speed Of Scoring Blade	8000 rpm	8000 rpm	8000 rpm
Scoring Motor	0.75kw (1HP)	0.75kw (1HP)	0.75kw (1HP)
Saw unit up/down	Automatic	Automatic	Automatic
Overall Dimensions	3250x3390x870mm	3250x3500x870mm	3250x3500x870mm
Total Power	9 Hp	9 Hp	9 Hp
Weight	750kg	1000kg	1300kg
Volatage	415 V	415 V	415 V

FULL FUNCTION HIGH EFFICIENT EXCELLENT PRECISION

MULTI BORING

Hi-202

Two Head Multi Boring



Hi-203

Three Head Multi Boring



SPECIFICATION

	Hi-202	Hi-203
Max. Drill Diameter	Max 35mm D=15mm	Max 35mm D=15mm
Max. Drilling Depth	H max=60mm	H max=60mm
Max. Processing Pitch	max.(LxB)150x640mm	max.(LxB)2400x672mm
Min. Processing Pitch	min. (LxB)135x32mm	min. (LxB)135x32mm
External Size	2300x2500x1560	2990x2500x1510
Pitch Of Drill Head	10MM	10MM
Spindle Speed	2840Rpm	2840Rpm
Total Number Of Drill Shaft	21X2	21X3
Total Power Of Motor	3KW	4.5 KW
Weight	750KG	900KG
Machine Damnation	2580x1300x1750	2580x1300x1750

FULL FUNCTION HIGH EFFICIENT EXCELLENT PRECISION

MULTI BORING

Hi-203 PLUS

Three Head Multi Boring



21 Boring Head



Smart Touch



Salient Features

- Easy setting of workpiece with instant & precised boring
- user friendly smart touch PLC control panel
- Two vertical heads, sliding and rolling guides, rotate by 90°

Hi-206 PLUS

Six Head Multi Boring



SPECIFICATION

	Hi-203 PLUS	Hi-206 PLUS
Max. Drill Diameter	Max 35mm D=3mm	Max 35mm D=3mm
Max. Drilling Depth	H max=60mm	H max=60mm
Max. Processing Pitch	max.(LxB)2400x672mm	max.(LxB)2400x672mm
Min. Processing Pitch	min. (LxB)135x32mm	min. (LxB)135x32mm
Pitch Of Drill Head	10MM	10MM
Spindle Speed	2840Rpm	2840Rpm
Total Number Of Drill Shaft	21X3	21X6
Total Power Of Motor	4.5 KW	9 KW
Weight	1250KG	2200KG
External Size	3480x2500x1560	4480x2500x1560



HING BORING & POSTFORM

Hi-111
Hing Boring



SPECIFICATION	Hi-111
Max. Drilling Diameter	35mm
Max. Drilling Depth	50mm
Max. Processing Length	1000mm
Drill Spindle Number	3x1
The Motor Power	1.1kw
Overall Dimensions	1100x700x1550mm
Weight	250kg

Hi-240
Postform

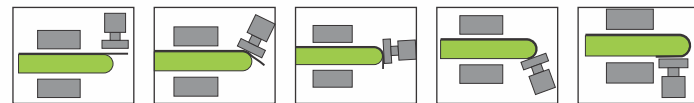

SPECIFICATION	Hi-240
Max. Length of Work Piece	2440 mm
Min. Length of Work Piece	600 mm
Work Piece thickness range	16 - 105 mm
Min. Work piece width	200 mm
max. Heating temperature	200 degree
Heating element	3.5 h.p
Electric Motor - 3 Phase	0.5 h.p



SPINDLE MOULDER

Hi-340
Spindle Moulder

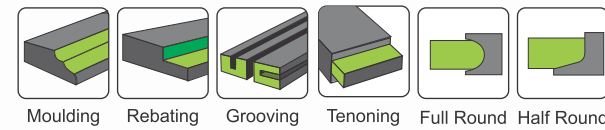

SPECIFICATION	Hi-340
Table Size	1200x750 (mm)
Spindle Diameter	35mm
Spindle Speed Up & Down Movement	100mm
Main Motor Power	5HP
Length Of Sliding Table	1220mm
Width Of Sliding Table	305x1220 (mm)
Spindle Rpm	5000/10000

Hi-330
Spindle Moulder

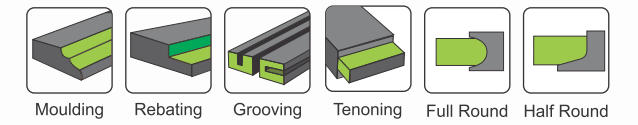

SPECIFICATION	Hi-330
Spindle RPM	10000R/min
Max. Working Thickness	150mm
Cutter Diameter	35mm
Motor Power	4/5.5 kw
Working Table Size	1130x680mm

SPECIFICATION			Hi-48
A	B	Speed Range	
21	44	0.4~9.6	
25	40	0.5~12.5	
40	25	1.3~32.2	Standard
44	21	1.7~42.2	Optional
Motor	0.7kw 5~120HZ/ 140~3360Rpm/ 380v~480v 1HP		
Roller Size	120x60mm(w) Bore 60mm		
Speed Control By	Inverter (VFD)		
Suspension	17mm		
Max. Roller Coverage	416mm		
Min. Length Allowed	165mm		
Machine Size	609 x 258 x 473		
Machine Size	301.3Kg		

Hi-48
Auto Feeder



COLD PRESS

Hi-50 T

Cold Press

4 Side Rack pinion Working platen insure uniform pressure increase life of cylinder



Hi-100 T

Cold Press



Salient Feature

- Top And Bottom platen designed to generate and Handle uniform pressure
- Robust & Heavy duty structure
- Manual And Auto system
- Motor protection circuit breaker for motor overload protection. Emergency Stop Arrangement

SPECIFICATION	UNIT	Hi-50T	Hi-100T
Platen size	mm	2500x1300	2500x1300
Max. pressure	Ton	50	100
Max. Platen Opening	mm	1000	1000
Total Power	Hp	5	7.5
Control		Manual/ Automatic	Manual/ Automatic
No. of Hydraulic Cylinders	Kw	2	4
Approx Weight	Kg	2400	3100
Overall dimensions	mm	2900x1330 x2850mm	2900x1330 x2850mm

Application

- M/c suitable for pressing various type of laminations on composite wood, cork board, fiber, honeycomb board.
- Having various applications for furniture & boards lamination industry.



HOT PRESS

Hi-120 T

HOT PRESS



SPECIFICATION	UNIT	HI-120 T
Max.load/pressure rating	Ton/kg-cm ²	120/3.6
Platen size	mm	2500×1300×42
Number of layers	nos	One
Opening between layers	mm	380
No.of hydraulic cylinders	nos	6
Size of hydraulic cylinders	mm	90Ø
Heating power	kw	18
Hot oil delivery pump power	kw	1.12
Hydraulic pump power	kw	4
Total power	Kw/hp	23.12/30.82
Machine dimension(L*B*H)	mm	3650×1650×2500

Hi-1250

Vacuum Membrane Press



SPECIFICATION	UNIT	HI-1250	HI-1252
Working table	Nos	1	2
Work table size	mm	2500×1250	2500×1250
Thickness of work piece	mm	50	50
Vacuum	mpa	-0.1	-0.1
Heating load	hp	26.6	26.6
Total power(3 phase)	hp	29.6	29.6
Machine dimension(L×B×H)	mm	6800×1850×1500	10600×3800×1700
Approx weight	kg	1200	1500

FULL FUNCTION HIGH EFFICIENT EXCELLENT PRECISION

HIGH SPEED ROUTER

Hi-90 R High Speed Router



Designed for high speed production routing getting clean, fast cuts while routing, moulding making dovetails, grooving, mortising, tenoning and rebating

SPECIFICATION	Hi-90 R
Max. Working Thickness	150mm
Max spindle stroke	65mm
Spindle RPM	18000r/min
Total power	5 hp

Hi-45 / Hi-52 Dust Collector

A dust collector removes dirt, dust, debris, gases and chemicals from the air, providing your factory with cleaner air, which can provide numerous benefits.

The Importance of Dust Collectors

- They Improve Health and Safety. ...
- They Increase Productivity. ...
- They Lead to Better Product Quality. ...
- They Help You Meet Compliance Regulations. ...
- They Help to Ensure Happier Employees.

SPECIFICATION	Hi-31/32	Hi-42	Hi-52	Hi-72
Total Power	3hp	4hp	5hp	7.5hp
Net Weight	50kg	55kg	90Kg	110Kg



Hi-60 CR Manual Corner Rounding



SPECIFICATION	Hi-60 CR
Spindle Speed	24000 rpm/min
Total Power	1hp
Voltage	220-240v
Working Pressure	4-6kg/ cm2
Power Supply	50Hz
Overall Dimensions	650x530x490mm
Net Weight	30kg



HUNNY IMPEX

FULL FUNCTION HIGH EFFICIENT EXCELLENT PRECISION

EDGE BANDER

Hi-200 Manual Edge Bander



SPECIFICATION	Hi-200
Table Size	1200x910 mm
Feeding Speed	5-18 m/min
Maximum Thickness Of Work Piece	10-60 mm
Mechanism For Tape Cutting	Pneumatic (automatic)
Glue Pot Capacity	3kg (Approx)
Heating Element	3kw
Edge Thickness	0.4 To 2 mm
Control Of Tape Cutting	Micro Switch On Table Foot Switch
Glue Can Be Applied	Tape & Board (both)
Machine Can Be Run On	Vfd Speed Port
Shape Of Working	Stright/Curved



Salient Features
Manual edge bander machine for application of PVC or Veneer on straight and curvilinear panel

Hi-50 P-PLUS Portable Edge Bander



SPECIFICATION	Hi-50 P-PLUS
Working Piece Thickness	7 to 60 mm
Machine Speed	1 to 6 mtr/min
Power	220 V
Weight	15 to 20kg
Glue Storage	1 kg
Motor Power	1.6 hp

Hi-50 P Portable Edge Bander



SPECIFICATION	Hi-50 P
Working Piece Thickness	7 to 60 mm
Machine Speed	1 to 6 mtr/min
Power	220 V
Weight	12 to 15kg
Glue Storage	1 kg
Motor Power	1.6 hp



FULL FUNCTION HIGH EFFICIENT EXCELLENT PRECISION



HUNNY IMPEX

AUTOMATIC EDGE BANDER

Hi-350

Semi Auto Edge Bander



Hi-400

Auto Edge Bander

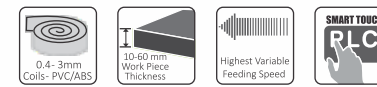

Salient Features

- **Stabilized production** even at max feeding speed of 25mtr/min due to sturdy machine structure
- smart touch **PLC control panel** for convenient use
- **Automatic up-down** movement of pressure beam for thickness setting
- In-built safety **AIR TANK** to avoid dropping of air pressure during process

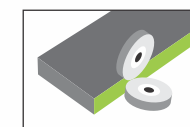

Buffing

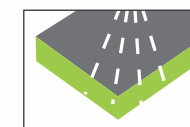

Spray Unit

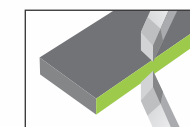

Scraping

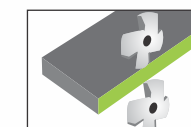

Fine Trimming

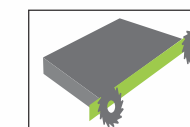

Front & Rear
End Cutting

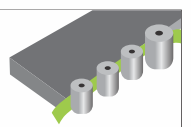

Banding

SPECIFICATION

	Hi-350	Hi-400
Working Thickness	10-60(mm)	10-60mm
Min. Working Width	60 mm	60mm
Min. Working Length	150m	150m
Band Strip Thickness	0.4-2mm	0.4-3mm
Feeding Speed	12m/min.	12m-16m-18m/min.
Working Air Pressure	6 to 8 kg/cm ²	6 to 8 kg/cm ²
Total Motor Power	6.2kw	7.9kw
Machine Dimension (L x B x H)	2800 x 1100 x 1600mm	3550 x 850 x 1350mm
Aprox net.Weight	800kg	1200kg

AUTOMATIC EDGE BANDER

Modular design, customized on demand, easy to operate

FULL FUNCTION HIGH EFFICIENT EXCELLENT PRECISION

AUTOMATIC EDGE BANDER

Hi-500
Auto Edge Bander



Hi-555 P
Auto Edge Bander

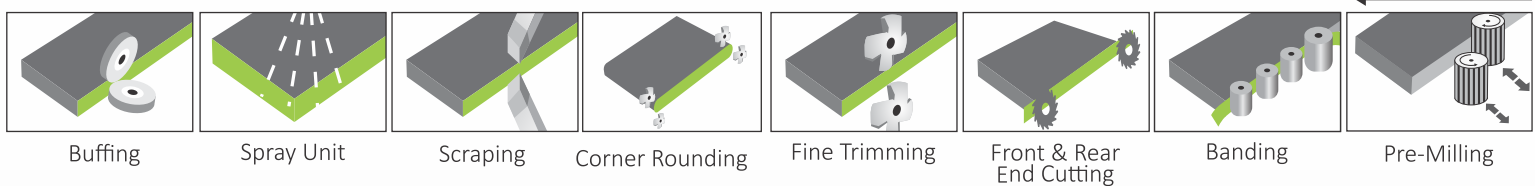
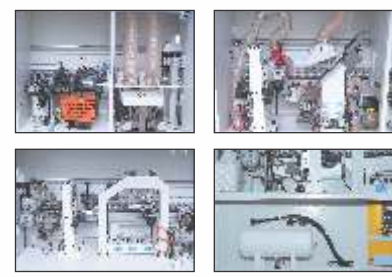

- Salient Features**
- Stabilized production even at max feeding speed of 25mtr/min due to sturdy machine structure
 - smart touch PLC control panel for convenient use
 - Automatic up-down movement of pressure beam for thickness setting
 - In-built safety AIR TANK to avoid dropping of air pressure during process
 - Low maintenance m/c, easily replaceable and cost effective spares
 - Also Available Premilling Unit with diamond milling cutter for chip free glue joint in HI-600P

SPECIFICATION	UNIT	Hi-500	Hi-555	Hi-555P
Working Thickness	mm	10-60(mm)	10-60	10-60
Min. Working Width	mm	60mm	60	60
Min. Working Length	mm	100m	100	100
Band Strip Thickness	mm	0.4-3mm	0.4-3	0.4-3
Feeding Speed	mtr/min	15-20-25	15-18-20	15-18-20
Working Air Pressure	kg/cm ²	6 to 8	6 to 8	6 to 8
Total Motor Power	kw	7.9	11.33	17.33
Pre-Milling motor	no/hp	N/A	N/A	2 x 3
Corner Radius Motor	no/hp	N/A	2 x 1	2 x 1
Machine Dimension (L x B x H)	mm	3550 x 850 x 1350mm	4350x1200 x1600mm	4850x1200 x1600mm
Fine Trimming motor	no/hp	—	2x1.5	2x1.5
Aprox net.Weight	kg	1200	1400	1750



FULL FUNCTION HIGH EFFICIENT EXCELLENT PRECISION

AUTOMATIC EDGE BANDER

Hi-600
Auto Edge Bander

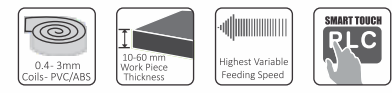

Hi-600 p
Auto Edge Bander

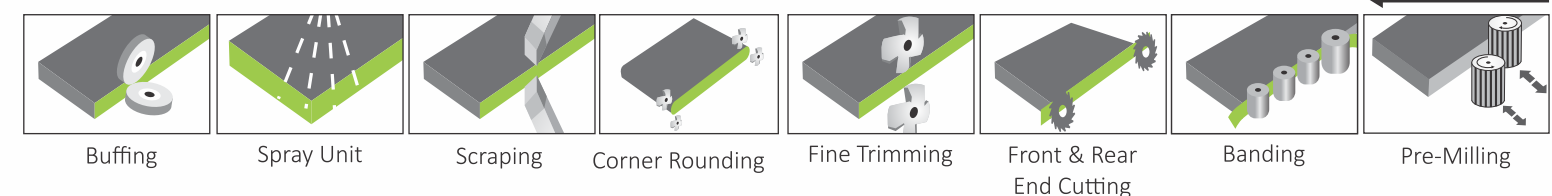

SPECIFICATION	UNIT	Hi-600	Hi-600P
Working Thickness	mm	10-60	10-60
Min. Working Width	mm	60	60
Min. Working Length	mm	100	100
Band Strip Thickness	mm	0.4-3	0.4-3
Feeding Speed	mtr/min	15-20-25	15-20-25
Working Air Pressure	kg/cm ²	6 to 8	6 to 8
Total Motor Power	kw	12.66	18.66
Pre-Milling motor	no/hp	N/A	2 x 3
Corner Radius Motor	no/hp	2 x 0.5	2 x 0.5
Machine Dimension (L x B x H)	mm	5550x1200 x1600mm	6000x1200 x1600mm
Fine Trimming motor	no/hp	2 x 1	2 x 1
Aprox net.Weight	kg	1700	2100

FULL FUNCTION HIGH EFFICIENT EXCELLENT PRECISION

AUTOMATIC EDGE BANDER

Hi-700 PUR

Auto Edge Bander

PUR gluing system is optional
Quick switch with EVA Coating



FULL FUNCTION HIGH EFFICIENT EXCELLENT PRECISION

AUTOMATIC EDGE BANDER

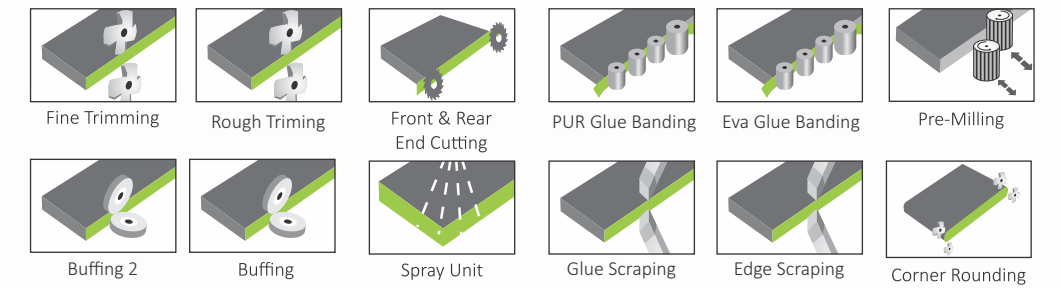

SPECIFICATION

SPECIFICATION	UNIT	Hi-700 PUR
Working Thickness	mm	10-60mm
Min. Working Width	mm	95
Min. Working Length	mm	120
Band Strip Thickness	mm	0.4-3.0
Feeding Speed	mtr/min	20-23-26 m/min
Working Air Pressure	kg/cm ²	0.6-0.8 mpa
Total Motor Power	kw	19.5 kw
Pre-Milling Motor	no/hp	2 X 3
Corner Radius Motor	no/hp	2 x 0.5
Machine Dimension (L x B x H)	mm	8400 x 910 x 1540mm
Fine Trimming Motor	no/hp	2 x 1
Flat Trimming Motor	no/hp	2 x 1
Aprox net.Weight	kg	2500 kg

OPTIONAL ATTACHMENT FOR Hi-600 & Hi-600P

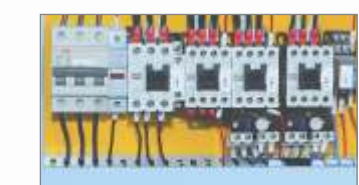

Smart Touch Operating Panel

Separate Frequency Converter

Schneider Electric Stable Operation

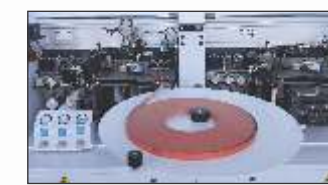

Delta PLC

Pre-milling

Separate Glue Tank for PUR Glue & EVA Glue

Auto Glue System



PUR GLUE TANK

Fine Trimming & Rough Trimming

Corner Rounding

Double Buffing

FULL FUNCTION HIGH EFFICIENT EXCELLENT PRECISION

AUTOMATIC EDGE BANDER

Hi-800 P
Auto Edge Bander



FULL FUNCTION HIGH EFFICIENT EXCELLENT PRECISION

AUTOMATIC EDGE BANDER

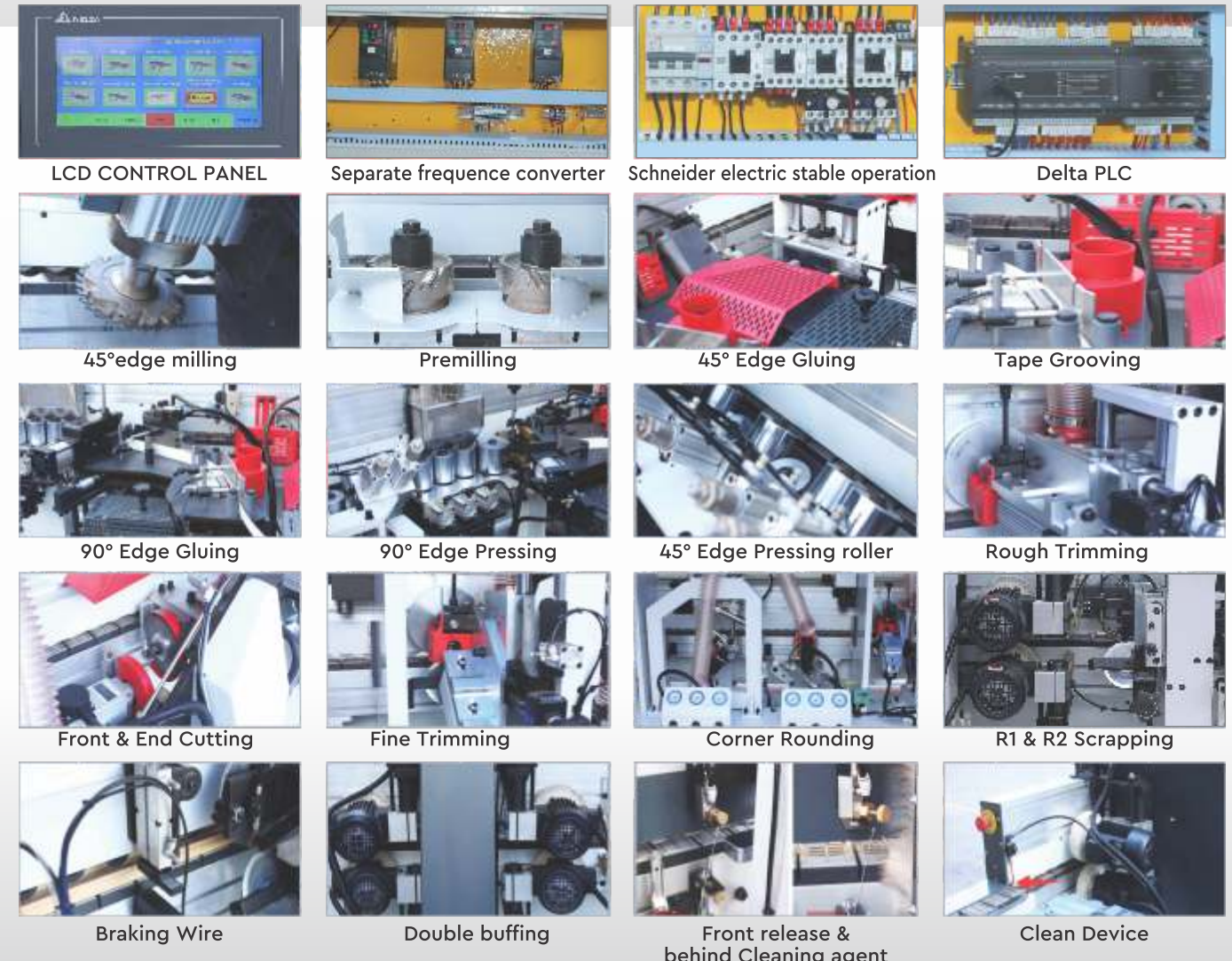
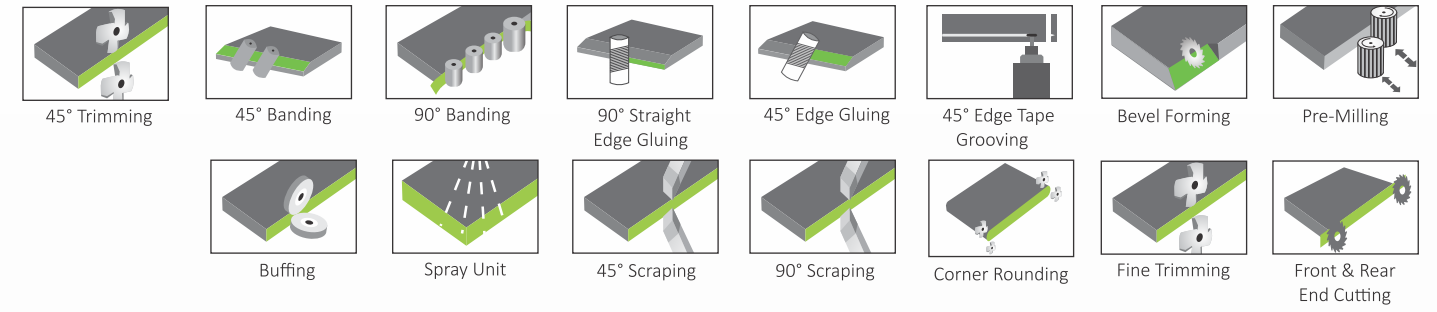

SPECIFICATION	UNIT	Hi-800 P
Panel pasting Angle	Degree	45 & 90
Working Thickness Range		
Inclined 45 Edge	mm	10 x 25
Full Straight Edge	mm	10 x 60
Working Size Width-Length		
Inclined 45 Edge	mm	120 x 150
Full Straight Edge	mm	80 x 120
Thickness For PVC/ABS in coil form		
Inclined 45 Edge	mm	0.4 x 2.0
Full Straight Edge	mm	0.4 x 3.0
Feeding Speed	Mtr/min	15-20-25
Pre-Milling motor	kw	2 x 3
45 Milling motor	kw	1 x 7.5
Corner Radius Motor	kw	2 x 0.5
Working Air Pressure	CFM	6 to 8
Machine Dimension (L x B x H)	mm	9300x1530 x1600
Total Power	kw	40.5
Aprox net.Weight	kg	3000



CNC ROUTING

Precision cutting, drilling and milling combined in one machine. Achieve flexible production

CNC ROUTER

Hi-1325 A CNC ROUTER



Suitable for

Carpentry work, wooden doors, furniture, cabinets etc...

Material used

MDF, Hardwood, Acrylic sheet, PVC sheet, Korean, ACP Sheet, Foam Sheet, Cement Sheet, Aluminum.

Salient Features

- Stepper/ Servo Motor and driver, **high precision** and speed
- **Air Cooled spindle** gives you very stable, trouble free and maintenance free performance for long time
- Fast speed and high accuracy ensured by **gear transmission** equipped on CNC router
- Manual lubrication maintenance provide by automatic **lubrication system**
- High accuracy and heavy work load ensured by **imported square rail**
- **Heavy Linear guide** for smooth operation high precision and long life
- T-Slot table can fix materials of different sizes effectively. Vacuum table is for optional

Also Available

Variable Size, Double Spindle, Four Spindle
Vacume tabel Bed, Rotary Attachment
Different Capacity spindle

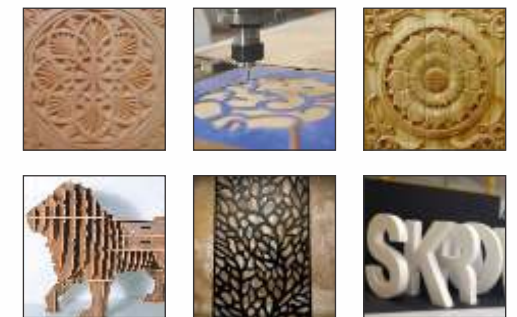

SPECIFICATION	Hi-1325 Stepper	Hi-1325 Servo
X-Y-Z Axis Working Area	1300x2500x250(mm)	1300x2500x250(mm)
X-Y Axis transmission	Rack & Pinion (Helical)	Rack & Pinion (Helical)
Z Axis transmission	Ball Screw	Ball Screw
Max. Working Speed	25000 mm/min	30000 mm/min
Max. Traveling Speed	30000 mm/min	35000 mm/min
Working Accuracy	± 0.02	± 0.01
Controller	DSP Rich Auto A11 E	DSP Rich Auto A11 E
Drivers & Motors	Stepper	Servo
Spindle Capacity	3.5 & 4.5 & 6 kw	3.5 & 4.5 & 6 kw
Spindle RPM	18000 RPM	18000 RPM
Command Code	G code,M code	G code,M code
Voltage	380V (3 Phase)	380V (3 Phase)
Panel Holding	T-Slot Clamping Vaccum Holding	T-Slot Clamping Vaccum Holding

CNC ROUTER

Hi-1325 DH DOUBLE HEAD CNC ROUTER



Suitable for

Carpentry work, wooden doors, furniture, cabinets etc...

Material used

MDF, Hardwood, Acrylic sheet, PVC sheet, Korean, ACP Sheet, Foam Sheet, Cement Sheet, Aluminum.

Salient Features

- Stepper/ Servo Motor and driver, **high precision** and speed
- Air Cooled spindle** gives you very stable, trouble free and maintenance free performance for long time
- Fast speed and high accuracy ensured by **gear transmission** equipped on CNC router
- Manual lubrication maintenance provide by automatic **lubrication system**
- High accuracy and heavy work load ensured by **imported square rail**
- 25mm Linear guide** for smooth operation high precision and long life
- T-Slot table can fix materials of different sizes effectively. Vacuum table is for optional

Also Available

Variable Size, Double Spindle, Four Spindle
Vacume tabel Bed, Rotary Attachment
Different Capacity spindle

Optional :



Roller Attachment



Rotary Attachment

SPECIFICATION

	Hi-1325DH Stepper	Hi-1325DH Servo
X-Y-Z Axis Working Area	1300x2500x250(mm)	1300x2500x250(mm)
X-Y Axis transmission	Rack & Pinion (Helical)	Rack & Pinion (Helical)
Z Axis transmission	Ball Screw	Ball Screw
Max. Working Speed	25000 mm/min	30000 mm/min
Max. Traveling Speed	30000 mm/min	35000 mm/min
Working Accuracy	± 0.02	± 0.01
Controller	DSP Rich Auto A11 E	DSP Rich Auto A11 E
Drivers & Motors	Stepper	Servo
Spindle Capacity	3.5 & 4.5 & 6 kw	3.5 & 4.5 & 6 kw
Spindle RPM	18000 RPM	18000 RPM
Command Code	G code,M code	G code,M code
Voltage	380V (3 Phase)	380V (3 Phase)
Panel Holding	T-Slot Clamping Vaccum Holding	T-Slot Clamping Vaccum Holding

CNC ROUTER

Hi-1325 R-ATC+BORING BORING CNC ROUTER



Operating Interface



Auto Tool Changer



Tools Holder Magazine



9kw Auto Tool Changing Spindle

SPECIFICATION

	Hi-1325 R-ATC+BORING
X-Y-Z Axis Working Area	1300x2500x200(mm)
X-Y Axis transmission	Rack & Pinion (Helical)
Z Axis transmission	Ball Screw
Max. Working Speed	40000 mm/min
Max. Traveling Speed	60000 mm/min
Spindle Capacity	9kw ATC spindle
Tool Magazine	12 tool holder
Spindle RPM	24000 RPM
Boring Spindle Drill	9 vertical Boring
Boring Head Power	1.5 kw
Controller/Driver/Motor	Weihong
Working Accuracy	±0.01
Command Code	G code,M code
Voltage	380V (3 Phase)
Vacuum Pump	7.5 kw
Oil lubrication	Automatic
Machine Dimension	4200x3400x2500mm
Approx Weight	3300 kg

FULL FUNCTION HIGH EFFICIENT EXCELLENT PRECISION

CNC ROUTER + BORING

Hi-1325 NESTING NESTING CNC ROUTER



EXTREME
ROUTE



6kw 2 Spindle + Boring Head



9 vertical Drill-bank



SPECIFICATION

Hi-1325 NESTING

X-Y-Z Axis Working Area	1300x2500x200(mm)
X-Y Axis transmission	Rack & Pinion (Helical)
Z Axis transmission	Ball Screw
Max. Working Speed	40000 mm/min
Max. Traveling Speed	60000 mm/min
Spindle Capacity	6kw (2 spindle)
Spindle RPM	24000 RPM
Boring Spindle Drill	9 vertical Boring
Boring Head Power	1.5 kw
Controller/Driver/Motor	Weihong
Working Accuracy	±0.01
Command Code	G code,M code
Voltage	380V (3 Phase)
Vacuum Pump	7.5 kw
Oil lubrication	Automatic
Machine Dimension	4200x3400x2500mm
Approx Weight	3200 kg

FULL FUNCTION HIGH EFFICIENT EXCELLENT PRECISION

CNC ROUTER

Hi-1325 L-ATC CNC ROUTER



EXTREME
ROUTE



Operating Interface



9kw Auto Tool Changing Spindle



Liner Type ATC

SPECIFICATION

Hi-1325 L-ATC

X-Y-Z Axis Working Area	1300x2500x250(mm)
X-Y Axis transmission	Rack & Pinion (Helical)
Z Axis transmission	Ball Screw
Max. Working Speed	40000 mm/min
Max. Traveling Speed	60000 mm/min
Spindle Capacity	9kw ATC spindle
Spindle RPM	24000 RPM
Controller/Driver/Motor	Weihong
Tool Magazine	12 tool holder
Working Accuracy	±0.01
Command Code	G code,M code
Voltage	380V (3 Phase)
Vacuum Pump	7.5 kw Air cool
Oil lubrication	Automatic
Machine Dimension	4200x3400x2500mm
Approx Weight	2900 kg

CNC HORIZONTAL BORING

Hi-210

CNC HORIZONTAL BORING



VINOD BHSAI AAPSE



Salient Feature

- Applied with **laser sensor**, It locates position precisely and improves accuracy of processing.
- Precision guide** rail runs smoothly.
- Advanced control system** provides high processing efficiency

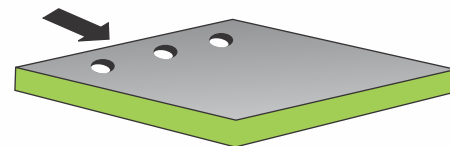

High-Speed Spindle



Laser Scanning Sensor



SPECIFICATION

SPECIFICATION	Hi-210
Working Size	2880 mm
Table Height	800 mm
Laser Sensor	Banner (American)
Spindle	2.2 kw
Traveling Speed	120 m/min
Working Speed	100 m/min ²
Motor Type	Servo
Motor Power	750w / 400w
Machine Dimension (L x B x H)	3300 x 1650 x 1350mm
Aprox net.Weight	800kg



HIGH SPEED BEAM SAW

Hunny Impex High Speed Beam Saw - Heavy duty pneumatic suspension grippers, avoiding scratch board surface. It can gripe the panel perfectly, highly

MANUAL BEAM SAW

Hi-280 M

HIGH SPEED MANUAL BEAM SAW



Operating Software



Air Floating Table



Dual Heavy Duty Saw Unit



Remote Controller

SPECIFICATION

Hi-280M

Dimension of board size	2750 X 2750mm
Speed of cutting	100m / min
Diameter of main saw blade	350 mm
Main spindle diameter	30 mm
Speed of main saw spindle	48 R.P.M
Diameter of scoring saw blade	180 mm
Scoring saw spindle diameter	25.4 mm
Speed of scoring saw spindle	6100 R.P.M
Max cutting height	85 mm
Working air pressure	0.6 - 0.7 mpa
Total motor power	15 kw
Voltage	415v
Weight	2600 Kg
Dimension	4900 x 3800 x 1800 mm

BEAM SAW

Hi-280

HIGH SPEED AUTO BEAM SAW



HD 19" LED Control Panel with Label printer



Aligner for Align Panel



Heavy Motor



Operating Software

Salient Feature

- **Hi-tech saw carriage** with high speed rate can be adjusted between 0-100mtr/min with high accuracy cutting
- **Robust, advanced balanced structure** offering high stability and guarantees precision & rigidity
- **Automatic lubrication system** which increases life span of parts



Fingers Clamp For Feeding



Main Saw & Scoring Saw Blade



Optimisation Software



Fingers Clamp For Feeding



Floating Table for Panel Movement

SPECIFICATION

	UNIT	Hi-280	Hi-320
Maxcutting Cutting Length	mm	2800	3200
Maxcutting Cutting Thickness	mm	100	100
Main Saw Blade Size	mm	ø400/ø60	ø400/ø60
Main Saw Shaft Rotation Speed	Rpm	4000	4000
Scoring Saw blade Size	mm	ø180/ø30	ø180/ø30
Scoring Saw Shaft Rotation Speed	Rpm	6900	6900
Saw Carriage Forward Speed	m/mm	100	100
Saw Carriage Backward Speed	m/mm	150	150
Main Saw Motor	kw	16	16
Saw Carriage Drive Motor	kw	2.2	2.2
Automatic Feeding Motor	kw	1 (servo)	1 (servo)
High-Pressure Blower Motor	kw	3	3
Side Aligner Motor	kw	0.25	0.25
Air Floating Table Quantity	Qty	3	3
Total Power	kw	22.45	22.45
Automatic Feeding Speed	m/mm	100	100
Air Pressure	kg/cm	5-7	5-7
Worktable Height	mm	960	960
Net Weight	kg	4500	5000
Machine Dimension (L x B x H)	mm	6000x5300 x1500	6000x6000 x1500

FULL FUNCTION HIGH EFFICIENT EXCELLENT PRECISION

BEAM SAW

Hi-280 PRO

HIGH SPEED AUTO BEAM SAW

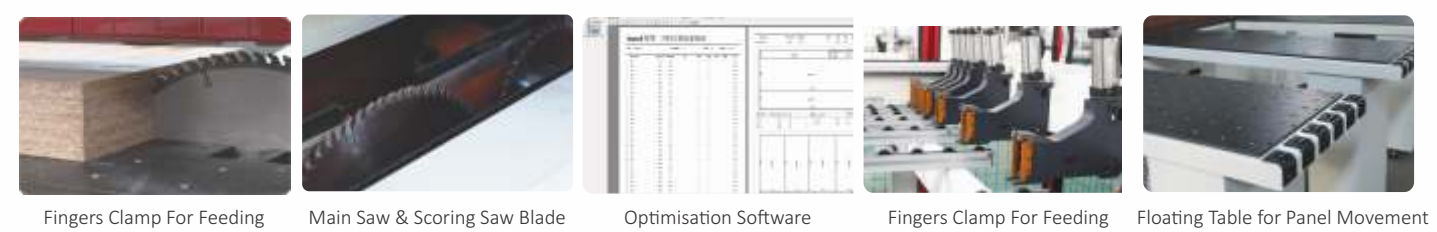
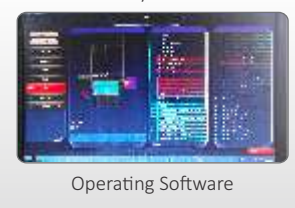
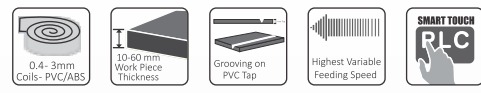

SPECIFICATION	UNIT	Hi-280 PRO
Maxcutting Cutting Length	mm	2800
Maxcutting Cutting Thickness	mm	120
Main Saw Blade Size	mm	ø400/ø60
Main Saw Shaft Rotation Speed	Rpm	4000
Scoring Saw blade Size	mm	ø180/ø30
Scoring Saw Shaft Rotation Speed	Rpm	6900
Saw Carriage Forward Speed	m/mm	120
Saw Carriage Backward Speed	m/mm	150
Main Saw Motor	kw	18.5
Saw Carriage Drive Motor	kw	2.2
Automatic Feeding Motor	kw	2 (servo)
High-Pressure Blower Motor	kw	3
Side Aligner Motor	kw	0.25
Air Floating Table Quantity	Qty	3
Total Power	kw	30
Automatic Feeding Speed	m/mm	100
Air Pressure	kg/cm	5-7
Worktable Height	mm	960
Net Weight	kg	4800
Machine Dimension (L x B x H)	mm	6000 x 5500 x 1800



FULL FUNCTION HIGH EFFICIENT EXCELLENT PRECISION

CNC BORING

Hi-612

SIX SIDE CNC BORING

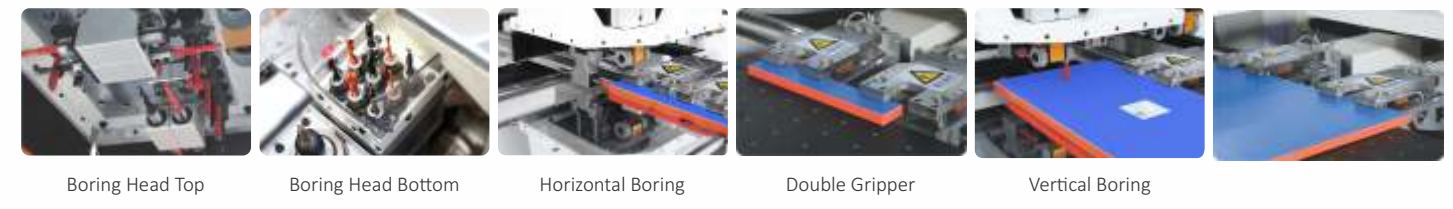
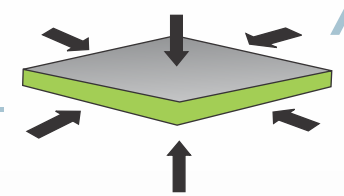

SPECIFICATION		Hi-612
Axis Travel & Maximum Positioning Speed	X & U Axis Max. Speed	5000mm & 130mtr/min
	Y Axis Max. Speed	1400mm & 80mtr/min
	Z Axis Max. Speed	100mm & 40mtr/min
	V Axis Max. Speed	900mm & 80mtr/min
	W Axis Max. Speed	100mm & 40mtr/min
	A Axis Max. Speed	950mm & 35mtr/min
Boring Head Configuration	Vertical Drill Bits Top	9 Drill
	Vertical drill bits Bottom	9 Drill
	Horizontal Drill Bits	2(L)+2(R) 2(F)+2(B)
	Boring Head speed	2800rpm
Spindle Configuration	Motor Power	2.2kw*2
	Spindle Power	3.5kw*2
	Spindle Speed	18000rpm
Processing Size Range	Max. Width of Panel	1200mm
	Min. Width of Panel	50mm
	Max. Length of Panel	5000mm
	Min. Length of Panel	250mm
	Max. Thickness of Panel	48mm
	Min. Thickness of Panel	12mm
Other Parameters	Total Power	18.9kw
	Working Voltage	380V/50Hz
	Working Pressure	0.7-0.8Mpa
	Approx Weight	2500kg
	Overall Size	6480*2840*2200mm

Hi-1325
NESTING



Design, Nesting, Optimization

Function description: Tailored specifically for custom furniture company user - friendly interface, simple design & complete production data.



Nesting CNC Router Machine

Function description: CNC control, single and double worktable, drilling box is optional for panel cutting, drilling, irregular shape processing.



Design, Cutting, Optimization

Function description: Tailored specifically for custom furniture company user - friendly interface, simple design & complete production data.

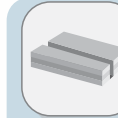

Auto Beam Saw Machine

Function description: Industrial computer control, multi order mixing, optimization cutting for mass production cutting, the labels can be printed at the same time

Hi-280 H



Hi-600P



- less capital investment
- Quality Production
- High Accuracy
- Saves Labor Cost
- Less Power Consumption
- Less Space Requirement
- Less Tooling Cost

Solution -1

Customized Production of Modular furniture, machines line solution

Solution -2

Mass Production panel furniture automation machines line solution

- Mass Production
- High Accuracy
- Saves Labor Cost
- Less Power Consumption
- Less Space Requirement
- Less Tooling Cost
- Double production as compared to solution-1

Hi-600P



Hi-210



Edge Banding machine

Function description: Automatic control, multi function straight edge banding for panel gluing, end cutting, rough trimming, fine trimming, scraping, buffing etc.

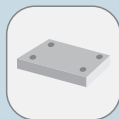

CNC Horizontal Boring Machine

Function description: Drilling in X Axis direction no length limit, double-clamping can complete the panel processing without changing clamp.



Edge Banding machine

Function description: Automatic control, multi function straight edge banding for panel gluing, end cutting, rough trimming, fine trimming, scraping, buffing etc.

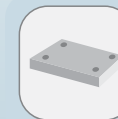

CNC Six Side Boring Machine

Function description: Drilling in X Axis direction no length limit, double-clamping can complete the panel processing without changing clamp.

Hi-612



MORTISER & TENONER

FULL FUNCTION HIGH EFFICIENT EXCELLENT PRECISION

Hi-1941 ROUND END TENONER

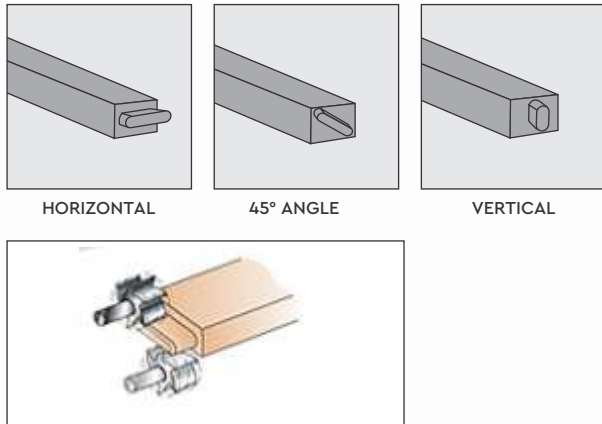

Standard Accessories :-
01 no. electric motor of 5 HP-2800 RPM-3 phase,
01 no. electric motor of 1 HP-1440 RPM-3 phase, control panel,
Hey duty cutter Set-1Nos, lubrication pump, meter gauge with
pneumatic clamping, air pressure regulator, Flat belt, toolkit & m/c manual.

Note : Use Dust collector with the m/c for superior performance.

Hi-1940 OSCILLATION MORTISER



SPECIFICATION	Hi-1941 mm/inch	Hi-1940 mm/inch
Mortise width-maximum	-	120/ 4.75'
Tenon width - maximum	100/4'	-
Tenon thickness - maximum	25/1"	-
Mortise depth-maximum	-	60/2.35'
Tenon depth - maximum	70/2.75'	-
Table Stroke	-	80/3.15'
Tenon diameter - maximum	25Φ	-
Spindle diameter	30Φ	-
Spindle speed- RPM	7800	9000
Tilting of table	-	± 20°
Adjusting angle of work table (Front)	10°	-
Adjusting angle of work table (Left & Right)	± 10°	-
Main motor power	3	3
Feeding motor power	1	-
Total power	4	3

Standard Accessories :-
Electric motor, control panel, collets- 2nos, drill bit- 2nos, lubrication pump,
pneumatic clamps, air pressure regulator, toolkit & m/c manual.

INNOVATIVE TOOLS FOR WOOD WORKING INDUSTRIES



PCD TOOLS



For high performance use tools by

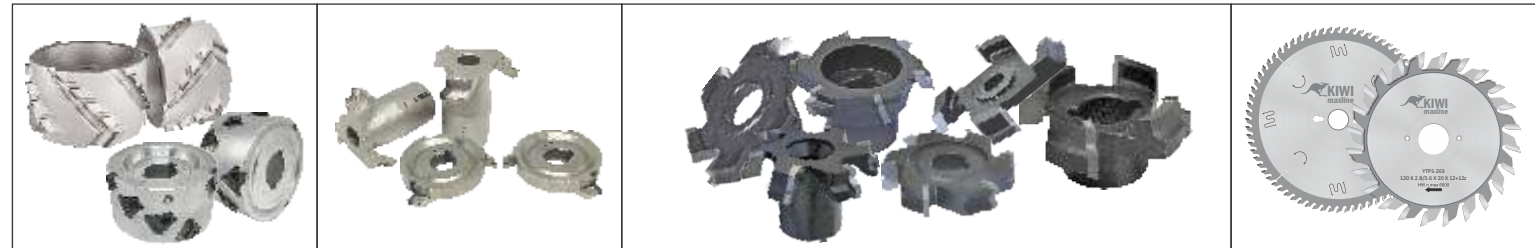

REPLACEABLE TOOLS



CNC & MULTIBORING ROUTER BITS



PANEL SAW & BEAM SAW BLADES



SPIRAL PLANING ROLL COLLET & KNIVES





HUNNY IMPEX

WOOD WORKING MACHINE SPARES

CHAIN PAD	CHAIN PAD	CHAIN PAD	CHAIN PAD	CHAIN PAD	CHAIN PAD
GRIPPER FOR 6 SIDE BORING	RUBBER ROLLER FOR AUTO EDGE BANDER	RUBBER ROLLER FOR AUTO EDGE BANDER	RUBBER ROLLER FOR AUTO EDGE BANDER	RUBBER ROLLER FOR AUTO EDGE BANDER	RUBBER ROLLER FOR AUTO EDGE BANDER
GRIPPER FOR 6 SIDE BORING	END CUTTING ROLLER FOR AUTO EDGE BANDER	FEEDING ROLLER FOR AUTO EDGE BANDER	FEEDING ROLLER FOR AUTO EDGE BANDER	BUFFING WHEEL FOR AUTO EDGE BANDER	BUFFING WHEEL FOR AUTO EDGE BANDER
BUFFING WHEEL FOR AUTO EDGE BANDER	END CUTTING STOPPER	END CUTTING STOPPER	FEEDING WHEEL	STEEL ROLLER	TRIMMING MOTOR
TRIMMING MOTOR	END CUTTING CYLINDER	SOLENOID VALVE	POSITION INDICATOR	POSITION INDICATOR	SUCTION PLATE
SUCTION PLATE	RUBBER SEALING	RUBBER SEALING	VACUUM POD FOR CNC	VACUUM POD FOR CNC	SUCTION PLATE
SUCTION PLATE	VACUUM BLOCK	VACUUM BLOCK	VACUUM POD FOR CNC	VACUUM POD FOR CNC	SCRAPER
LOCATING RING FOR CNC	FLAG STOPPER	MAGNIFIED GLASS	DRO	DEGREE INDICATOR	WOOD CLAMP

AVAILABLE SPARE PART FOR

- PANEL SAW MACHINE
- CNC ROUTER MACHINE
- COLD PRESS MACHINE
- CNC BORING MACHINE
- MULTI BORING MACHINE
- EDGE-BANDER MACHINE
- HOT PRESS MACHINE
- BEAM SAW MACHINE

MULTI BORING SCALE	TILTING INDICATOR	DRO ASSEMBLY	PARALLEL RIPPER	CROSS CUT RIPPER	CUTTER UPDOWN MOTOR
MITRE FENCE ASSEMBLY	PUSHER FOR PANEL SAW	KNIFE FOR PANEL SAW	DUST HOOD	HAND WHEEL	FLAG STOPPER
EUROPEAN DUST HOOD	FLAG STOPPER	SLIDING ROLLER	ARM ROLLER	PENCIL HEATER	HEATING PLATE
CARDIAN JOINT	LIMIT SWITCH	ADJUSTABLE HANDLE	MANUAL TRIMMER	MANUAL TRIMMER	TRIMMER KNIFE
MANUAL CUTTING	MANUAL TRIMMER	2R BIT	AIR FLOATING BALL	BEAM SAW RUBBER STRIP	RUBBER RING FOR CNC
DUSTPROOF FOR BEAM SAW	FLOATING TABLE ROLLER	SUPPORTING TABLE ROLLER	CLAMP PAD FOR MULTI BORING	BRACKET ROLLER	GLUE APPLICATOR
KNOB FOR PANEL SAW	CNC SENSOR	LEAD SHINE DRIVE	SPINDLE FOR CNC	INVERTER	OIL PUMP
MANUAL OIL PUMP	AUTOMATIC OIL PUMP	BELT	TOOL HOLDER CLAMP	MOTOR	2811MA DRIVER

One Stop Solution For Machine Tools & Spares